

L14 Lighting Coil

Yamaha WR250 90-95, YZ250 90-95

FITTING INSTRUCTIONS

READ THESE INSTRUCTIONS COMPLETELY

- Step 1** Take the ignition cover off. If you are replacing an existing lighting coil check the new part is similar to the old one and that they match, including the mounting hole locations. If not, double check the application listing with your bike.
- Step 2** Remove the flywheel using a proper puller tool and remove the base-plate with the original coils.
- Step 3** If you are replacing an existing lighting coil cut the original cables close to the original coil and remove from the base-plate.
- Step 4** Mount the new lighting coil onto the base plate, fit the screws making sure the ground tag is secured by a screw. Use locking compound on the threads and **tighten the screws securely!**

- Step 5** The lighting output cable is the yellow cable. You can run it straight to the lighting system, however it is better to use a 12V-AC regulator (RG12) parallel in circuit (see below). Make sure you have a good connection here. Crimp or solder connections as appropriate. When crimping the connections use high quality crimps. If soldering use a resin core solder (the type used in electrical applications) but be aware that solder doesn't always work very well on older cables. If appropriate insulate the cable connections with a heat shrinking sleeve.
- Step 6** Refit the stator base-plate. Ensure the cables cannot touch the flywheel (especially on the inside of the flywheel).
- Step 7** Refit the flywheel. Tighten the bolt to specified torque.
- Step 8** Connect the cables to the wiring loom on the bike.
- Step 9** Fit the ignition cover.

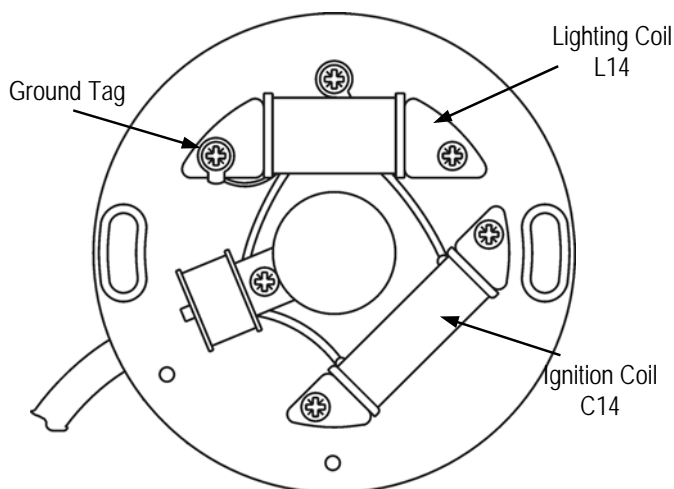

TROUBLESHOOTING

No lights? Check earth continuity with the engine. If necessary add an extra earth cable between the engine and the frame.

If the lighting still does not work: Re-check the connections. Making sure they were carefully crimped or soldered.

Note: With AC lighting systems the output varies with the engine speed, don't expect bright lights at tick over speed.

To prevent bulbs blowing we recommend you fit a regulator (RG12) to your bike. Ring 01491 682369 to order one now.

