

# C16/C56 Ignition Coils

Yamaha YZ250 1988-89



## FITTING INSTRUCTIONS

### READ THESE INSTRUCTIONS CAREFULLY

- Step 1** Take the ignition cover off. Check the new parts are similar to the old ones and that they match, including the mounting hole locations. If not, double check the application listing with your bike.
- Step 2** Make a note of the cable colours from the original stator and disconnect them from the wiring loom.
- Step 3** Remove the flywheel using a proper puller tool and remove the base-plate with the original coils.
- Step 4** Remove the screws that secure the ignition coils and take the coils off.
- Step 5** Cut the original cables close to the original ignition coils. Make a note of which cable colour goes to which side of the original coils.
- Step 6** Mount the coils onto the base plate, making sure the ground tag on the C16 is held in place with a mounting screw. Fit the screws using locking compound on the threads and **tighten securely!**
- Step 7** Connect the old cable to the new coil in exactly the same place as on the original, making sure you have a good connection. Crimp or solder connections as appropriate. When crimping the connections use high quality crimps. If soldering use a resin core solder (the type used in electrical applications) but be aware that solder doesn't always work very well on older cables. If appropriate insulate the cable connections with a heat shrinking sleeve.
- Step 8** Refit the stator base plate. Ensure the cables **cannot touch the flywheel** (especially on the inside of the flywheel).
- Step 9** Refit the flywheel. Tighten the bolt to specified torque.
- Step 10** Connect the cables to the wiring loom on the bike.
- Step 11** Fit the ignition cover.

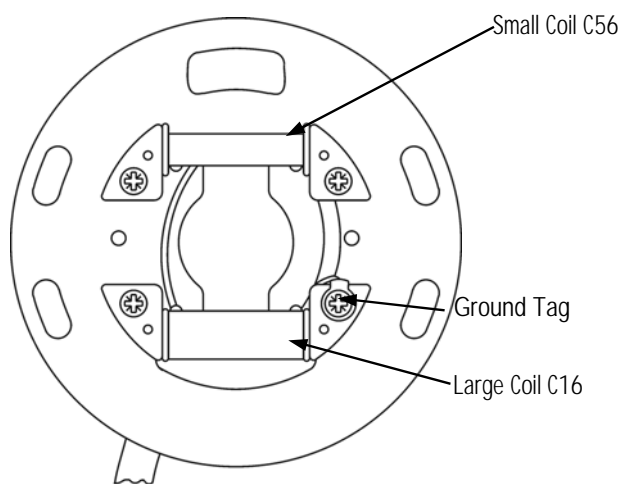
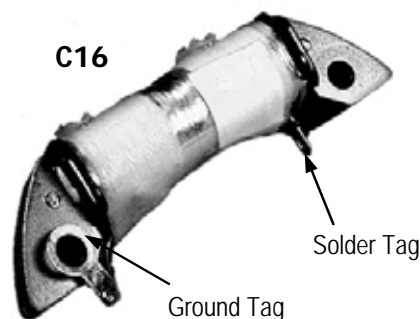
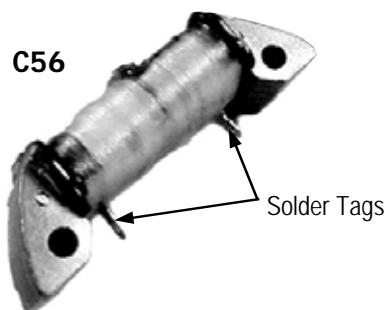

CONNECTIONS	
Existing wiring	On C16 connect to
BROWN	SOLDER TAG
Ground tag is secured under mounting screw	
Existing wiring	On C56 connect to
WHITE/RED	SOLDER TAG
Other side is either grounded or connected over to the C16 over a <b>BROWN</b> jumper cable. You will have to check the original set-up on your base plate as Yamaha used different settings.	

## TROUBLESHOOTING

**Engine will not start:** You may have connected the source coil cables in the wrong position. Swap the connections, re-solder the cables and the engine should start.

**If the engine still does not start:** Re-check the connections. Make sure you carefully crimp or solder the connections. Twisting cables together or taping cables may cause a poor spark or no spark at all.

If you still cannot get the engine to start, have all your testing