

# C10/C59 Ignition Coil

Honda CR125 1986-89, CR250 1986-88  
and CR500 1986

## FITTING INSTRUCTIONS

### READ THESE INSTRUCTIONS CAREFULLY

- Step 1** Take the ignition cover off. Check the new parts are similar to the old ones and that they match, including the mounting hole locations. If not, double check the application listing with your bike.
- Step 2** Make a note of the wire colours from the original stator and disconnect them from the wiring loom.
- Step 3** Remove the flywheel using a proper puller tool and remove the base-plate with the original stator.
- Step 4** Remove the screws that secure the ignition coils and take the coils off.
- Step 5** Cut the original wires close to the original coil. Make a note of which wire colour goes to which side of the original coils.
- Step 6** Mount the coils onto the base plate, fit the screws using locking compound on the threads and **tighten securely!**

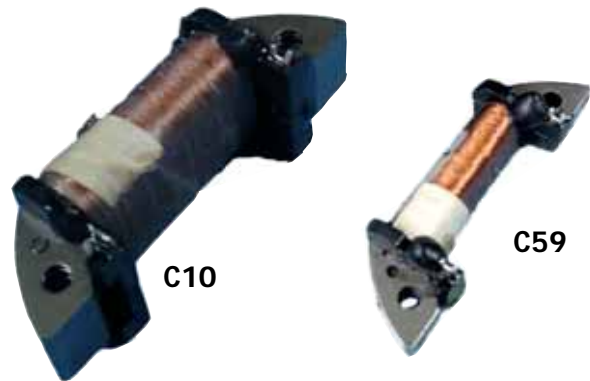

### CONNECTIONS

- C10** **large coil** connects to the original **BROWN** wire and the original white wire.
  - C59** **small coil** connects through a brown jumper lead to the C10 coil and to the original **BLUE** wire. Look at line drawings and compare to your set-up.
- Step 7** Connect the old cable to the new coil in exactly the same place as on the original, making sure you have a good connection. Crimp or solder connections as appropriate. When crimping the connections use high quality crimps. If soldering use a resin core solder (the type used in electrical applications) but be aware that solder doesn't always work very well on older wires. If appropriate insulate the wire connections with a heat shrinking sleeve.
- Step 8** Refit the stator base plate. Ensure the wires **cannot touch the flywheel** (especially on the inside of the flywheel).
- Step 9** Refit the flywheel. Tighten the bolt to specified torque.
- Step 10** Connect the wires to the wiring loom on the bike.
- Step 11** Fit the ignition cover.

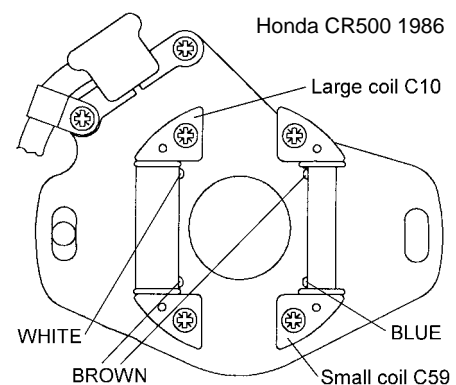
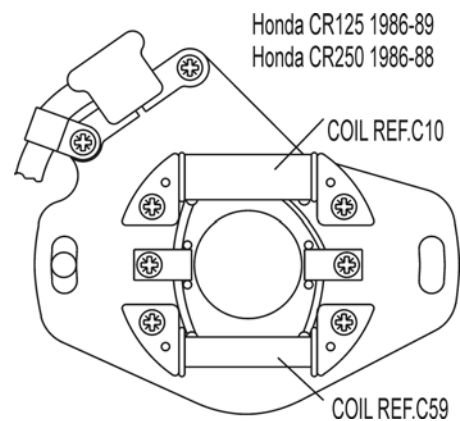

### TROUBLESHOOTING

**Engine will not start:** You may have connected the source coil cables in the wrong position. Swap the connections, re-solder the cables and the engine should start.

**If the engine still does not start:** Re-check the connections. Make sure you carefully crimp or solder the connections. Twisting cables together or taping cables may cause a poor spark or no spark at all.

If you still cannot get the engine to start, have all your testing information ready prior to calling the dealer or Electrex World.