

# C61/C62 Ignition Coil

## Yamaha YZ125/250 1977-1986



### FITTING INSTRUCTIONS

#### READ THESE INSTRUCTIONS CAREFULLY

- Step 1** Take the ignition cover off. Check the new parts are similar to the old ones and that they match, including the mounting hole locations. If not, double check the application listing with your bike.
- Step 2** Remove stator plate from the engine. Remove the four screws that hold the two coils in place and remove the coils with all wiring.
- Step 3** The rubber grommet can be taken off the original stator harness and fitted to the new cables using new sleeving and connectors.
- Step 4** Fit the screws. Use locking compound on the threads and **tighten the screws securely!**
- Step 5** Ensure the cables **cannot touch the flywheel** (especially on the inside of the flywheel).
- Step 6** Fit the ignition cover.

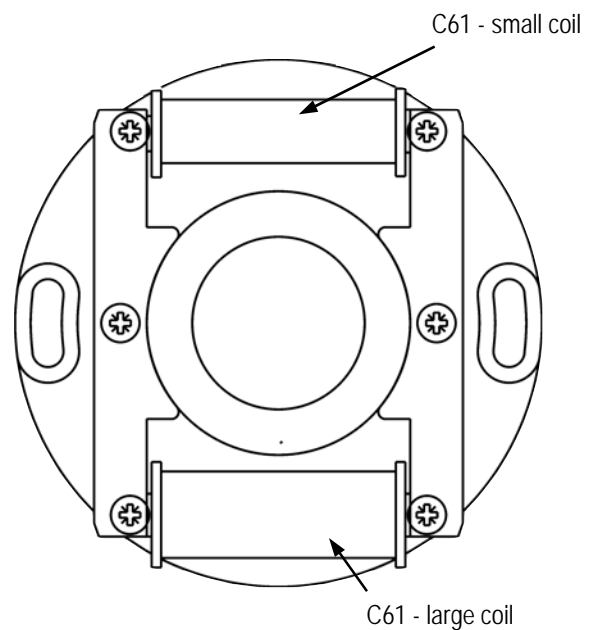
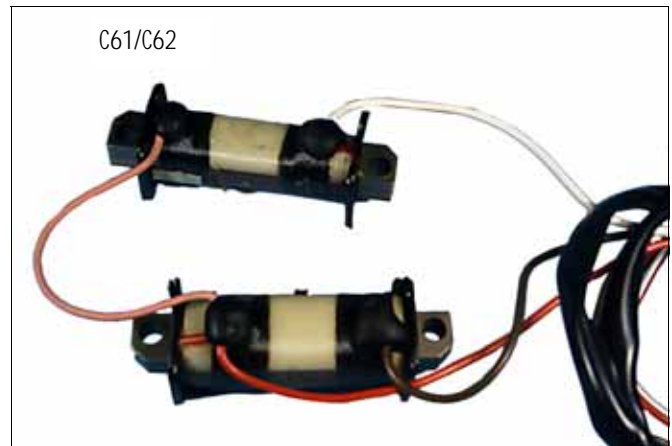

#### TROUBLESHOOTING

**Engine will not start:** You may have connected the source coil cables in the wrong position. Swap the connections, re-solder the cables and the engine should start.

**If the engine still does not start:** Re-check the connections. Make sure you carefully crimp or solder the connections. Twisting cables together or taping cables may cause a poor spark or no spark at all.

If you still cannot get the engine to start, have all your testing information ready prior to calling the dealer or Electrex World.