

# C11/C51 Ignition Coil

Kawasaki KX80/100 81-88, KX125 87-88

KX250 81-88, KX500 86-89

Yamaha YZ80 85 onwards, YZ125 90-91



## FITTING INSTRUCTIONS

### READ THESE INSTRUCTIONS CAREFULLY

- Step 1** Take the ignition cover off. Check the new parts are similar to the old ones and that they match, including the mounting hole locations. If not, double check the application listing with your bike.
- Step 2** Make a note of the cable colours from the original stator and disconnect them from the wiring loom.
- Step 3** Remove the flywheel using a proper puller tool and remove the base-plate with the original stator.
- Step 4** Remove the screws that secure the ignition coils and take the coils off.
- Step 5** Cut the original cables close to the original coil. Make a note of which cable colour goes to which side of the original coils.
- Step 6** Mount the coils onto the base plate, making sure the ground tag on the C11 is held in place with one of the mounting screws. Fit the screws using locking compound on the threads and **tighten securely!**
- Step 7** Connect the old cable to the new coil in exactly the same place as on the original, making sure you have a good connection. Crimp or solder connections as appropriate. When crimping the connections use high quality crimps. If soldering use a resin core solder (the type used in electrical applications) but be aware that solder doesn't always work very well on older cables. If appropriate insulate the cable connections with a heat shrinking sleeve.
- Step 8** Refit the stator base plate. Ensure the cables **cannot touch the flywheel** (especially on the inside of the flywheel).
- Step 9** Refit the flywheel. Tighten the bolt to specified torque.
- Step 10** Connect the cables to the wiring loom on the bike.
- Step 11** Fit the ignition cover.

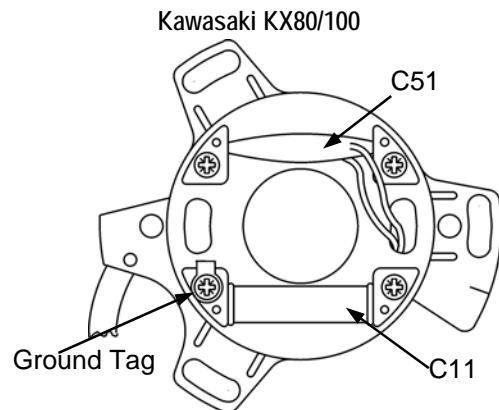
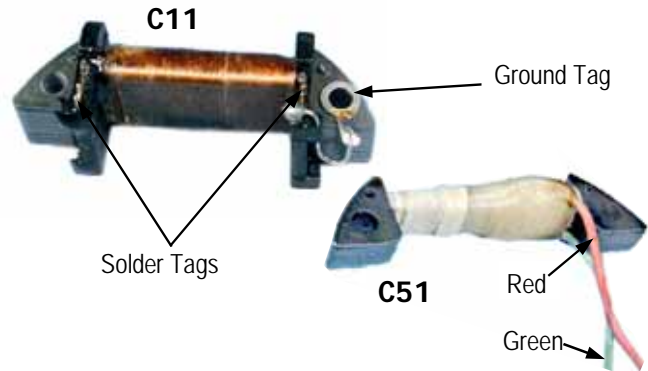

Kawasaki KX125/250/500 & Yamaha YZ80 (85 onwards), YZ125 (90-91)

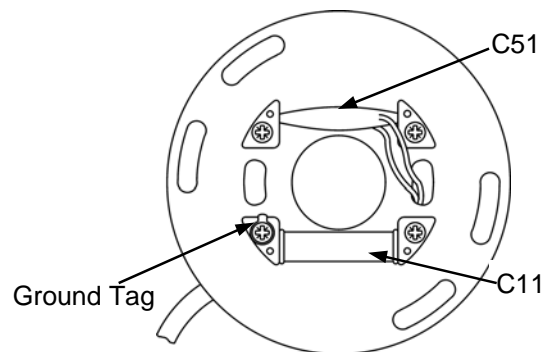

CONNECTIONS	
Existing wiring on large coil	On C11 connect to
BLACK/RED	RED
Connect the Ground Tag (black cable) under the coil mounting screw	
Existing wiring on small coil	On C51 connect to
WHITE/GREEN	GREEN
RED/WHITE	RED

### TROUBLESHOOTING

**Engine will not start:** You may have connected the source coil cables in the wrong position. Swap the connections, re-solder the cables and the engine should start.

**If the engine still does not start:** Re-check the connections. Make sure you carefully crimp or solder the connections. Twisting cables together or taping cables may cause a poor spark or no spark at all.

If you still cannot get the engine to start, have all your testing